

**Overrunning, Indexing, Backstopping
 Bearing Envelope (60 Series) Design, Ramp & Roller Clutches**



Sealed unit

Model ASK is a ramp & roller type clutch bearing supported by two rows of roller bearings. It is a self contained and dust protected unit, shipped grease lubricated.

Nominal outside envelope dimensions are the same as a 60 Series bearing.

Torque transmission must be accomplished by a press fit on both the inner and outer race. Because of this press fit, the standard radial clearance is C4.

The interference fit tolerances on the clutch envelope, allow for a direct mounting in a standard Series 60 bearing location.

Shaft tolerance should be h6 or j6. The outer race should be pressed into a rigid housing to K6 tolerance.

Radial bearing load capacities are given in the table.

Model ASK clutches can not accept axial loading. In cases of such loads, thrust bearings must be provided.

Specifications

Size	Bearing Series	Torque Capacity lb.ft. (Nm)	Max. Overrunning Speed		Resistance after run-in lb.in. (Ncm)	Lubrication	Shipping Weight lb. (kg)
			Outer Race RPM	Inner Race RPM			
40	6008	53 (72)	3,500	1,400	13.28 (15)	Grease	0.55 (0.25)
50	6010	92 (125)	3,000	1,400	17.70 (20)	Grease	0.75 (0.34)
60	6012	185 (250)	2,500	1,400	22.12 (25)	Grease	1.10 (0.5)

Typical Mounting Arrangement

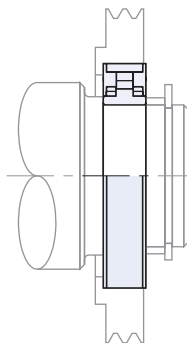

The ASK clutch must be mounted with a press fit on both the outer and inner race. The shaft diameter tolerance must be held to h6 or j6. The bore of the housing for the outer race should be a K6 tolerance.

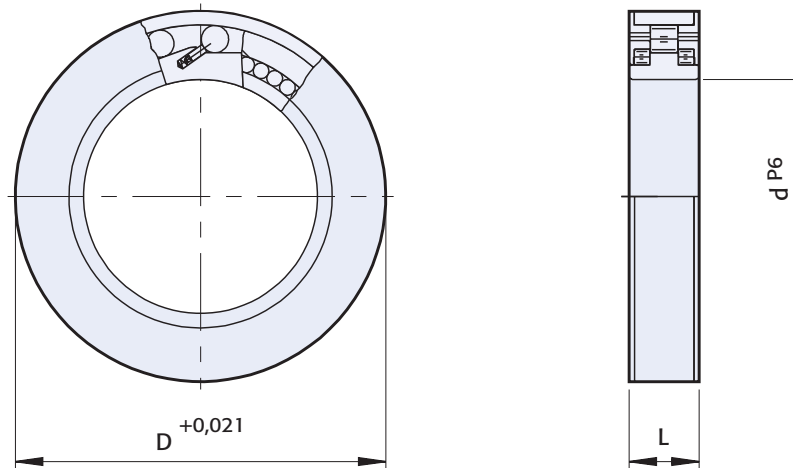

Dimensions inches (mm)

Size	D in. (mm)	L in. (mm)	Bearing Loads	
			Dynamic lb. (kN)	Static lb. (kN)
40	2.68 (68)	0.59 (15)	3645 (16.2)	4635 (20.6)
50	3.15 (80)	0.63 (16)	4410 (19.6)	5287.5 (23.5)
60	3.74 (95)	0.71 (18)	5692.5 (25.3)	7897.5 (35.1)

Bore sizes and keyseats inches (mm)

Size	d ^{P6} Bore Size	Keyseat ⁽¹⁾
40	1.57 (40)	None
50	1.97 (50)	None
60	2.36 (60)	None

⁽¹⁾ Press fit is required; see Typical Mounting Arrangement, page 28.